



SwiftAir 
Lifting people

*Design, supply &
installation of ceiling
hoist systems*

by **SwiftTech**™
Raising the standard



Lifting people

Design, supply and installation of ceiling hoist and tracking systems from leading suppliers worldwide.

Who are SwiftAir?

Over the past 18 years, SwiftAir have established a leading position in providing ways to lift, move and position disabled people in a variety of different caring environments.

SwiftAir offer an extensive range of ceiling hoists, patient hoists, tracking hoists, lifting equipment and hygiene systems from leading suppliers worldwide. To ensure you receive the best solution for your project requirements we also offer consultancy backed up with a comprehensive range of support services.

As specialists in PFI (Private Finance Initiative) Procure 21 and LIFT projects we understand the importance of sustainability and we focus on delivering efficient, high quality solutions.

Areas of specialty include the supply and installation of ceiling hoist and hygiene equipment for hospitals, nursing homes, day centre's, schools, hospices, dental surgeries and private clients.

SwiftAir can provide you with...the complete package for the complete solution.

Our services include:-

- Product advice
- Product demonstrations and evaluations
- Planning and design
- Cost analysis
- Project management
- Installation
- After sales maintenance and support

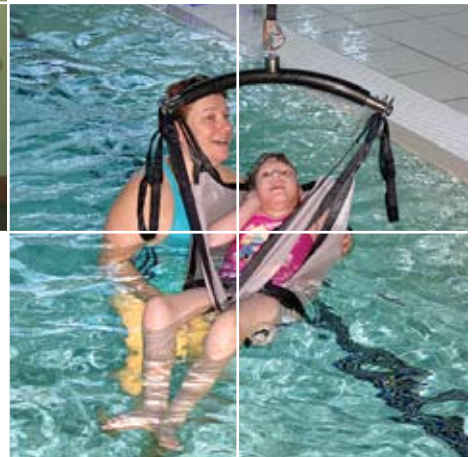

Contact our sales team direct for further details or a competitive quote

01225 792 650

info@swifttechhoists.co.uk

www.swifttechhoists.co.uk

The new ST2000 range from SwiftAir...

The new ST2000 range of ceiling hoists exclusively from SwiftAir mark a significant advance in the world of patient handling. The world class design and state of the art features ensures safe, reliable and effective hoisting for patients and carers alike. The small, compact and aesthetically pleasing design together with the extensive range of track configurations and opportunities make this system one of the most versatile available on the market today.

Some of the features include:-

- Small and aesthetically pleasing design
- Four weight capacities - 130kg, 160kgs, 200kgs, 280kgs
- Very low profile hoist module giving greater lifting height
- Available either manual or powered traversing options with slow start / stop
- State of the art LED display with lift counter
- Manual and powered emergency override operation
- Diagnostics facility for user and service engineer
- Pneumatically operated hand control for wet environments
- Service due indicator
- Two year warranty

Ergonomically designed handset for safe use in wet environments



Manual emergency lowering in the event of power failure for total peace of mind



Neat secure spreader bar system



LED display provides vital information for the user and carer

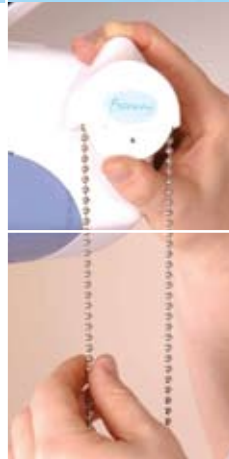

Discreet automatic end of rail charging station with integral transformer - IP67 rated



SwiftAir can provide solutions virtually anywhere...

...we can even integrate into the ceiling construction...

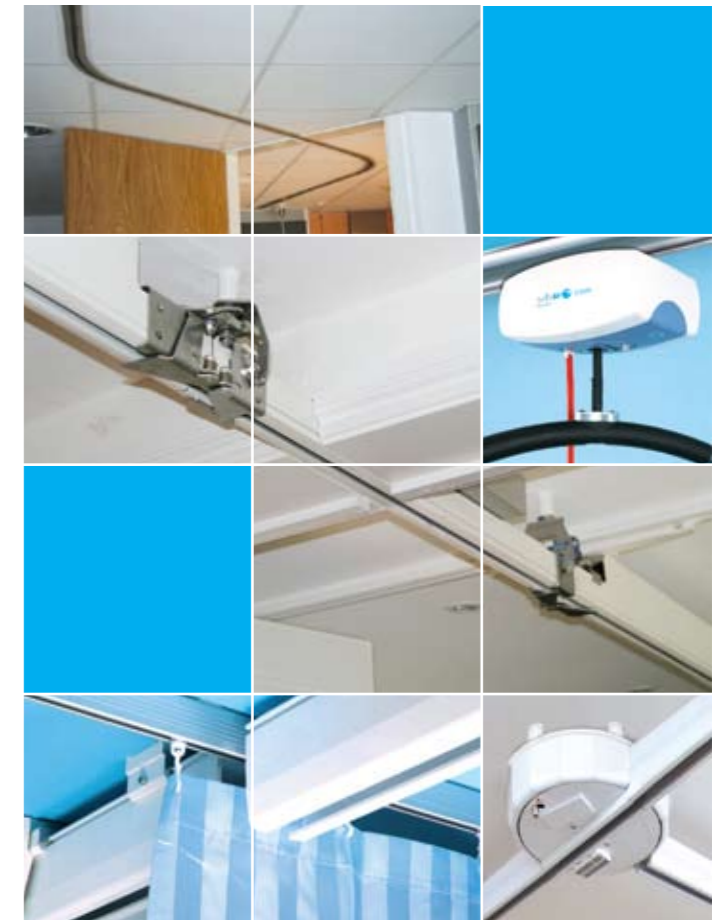
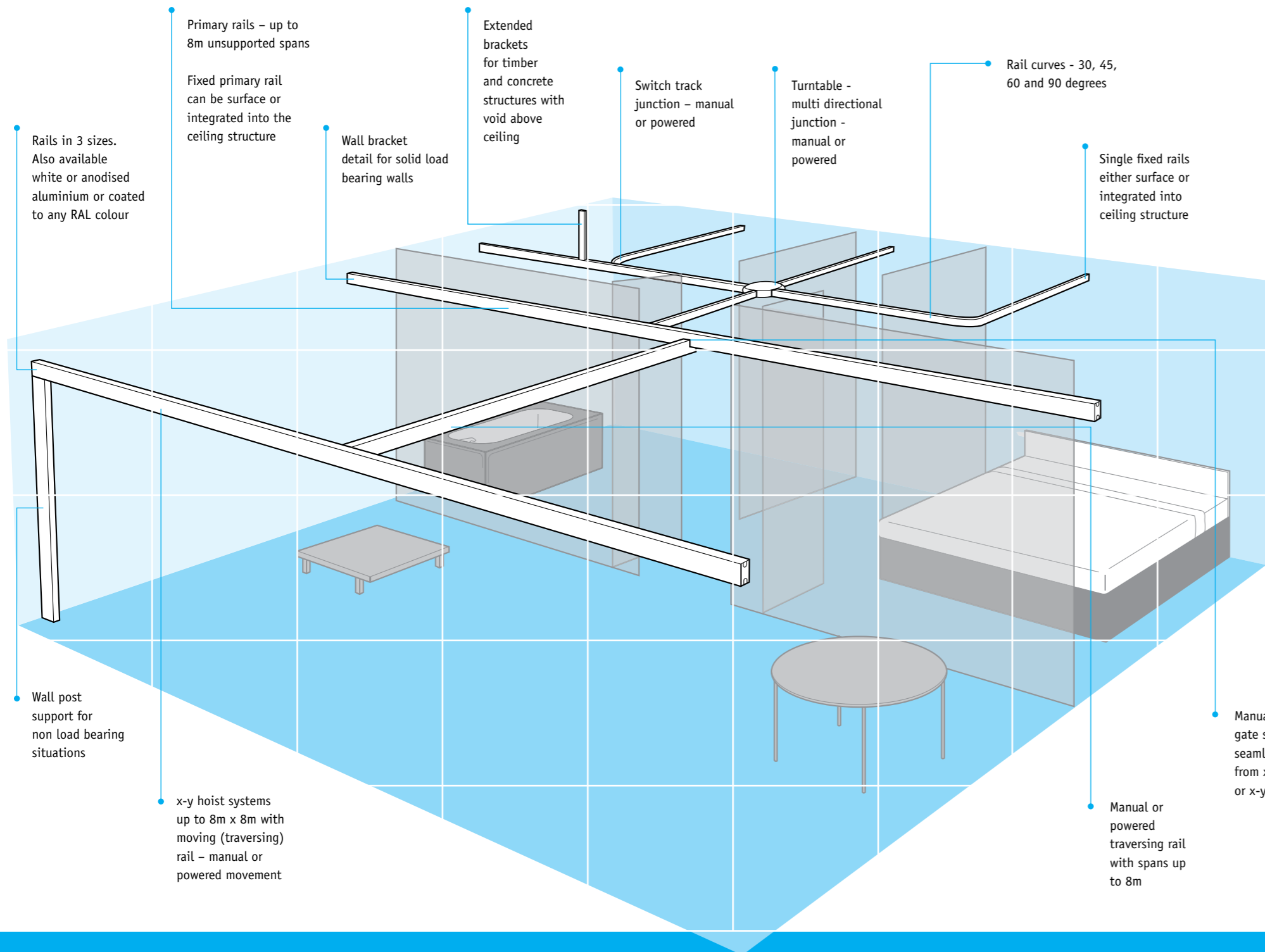

...with a vast range of rail systems available...

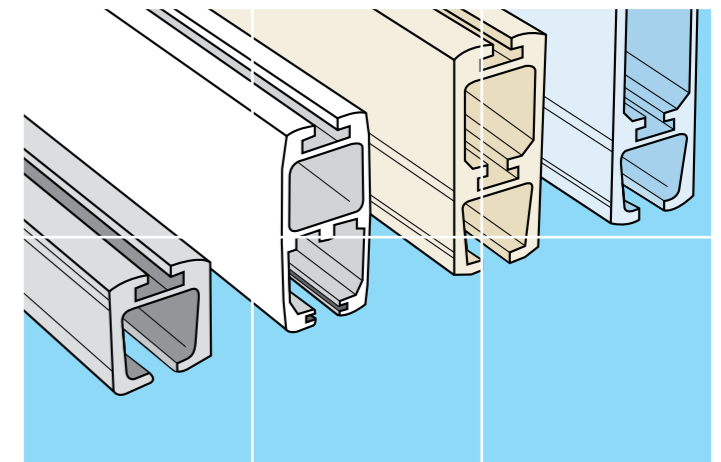

...the complete solution!

An approved **NHS** supplier

01225 792 650
 info@swifttechhoists.co.uk
 www.swifttechhoists.co.uk

SwiftAir
 Lifting people

by **SwiftTech**
 Raising the standard

V5 Duo from SwiftAir...

The new V5 duo is equipped with the unique feature of two weight capacity options. The V5 Duo is supplied as standard with a weight capacity of 100kgs and has the option to increase the lifting capacity to 200kgs, this enables the system to be adapted to various care environments, either at home or in the care home and a smaller less obtrusive rail can be used.

Small and sleek design which blends in well to any home environment



The new V5 Duo handset is ergonomically designed for ease of use. The casing allows a degree of water infiltration protection, also, the new tactile membrane withstands high usage. The cable is resistant to stretching and retracts to it's original length.

Unique self powering auto gate system allowing safe and seamless transfer from x-y system to fixed or another x-y system

Self powered turntable providing multi directional options

Self powered switch tracks giving added flexibility where more than one location requires access



Contact our sales team direct for further details or a competitive quote

01225 792 650

info@swifttechhoists.co.uk

www.swifttechhoists.co.uk



A Hill-Rom Company

Liko from SwiftAir...

SwiftAir are pleased to be able to offer the Liko quality range of ceiling hoists to our customers.

Liko is a well known established product and benefits from an extensive range of ceiling hoist systems together with specialist bariatric options that can lift up to 500kgs plus.

This Swedish manufacturer offers excellent solutions for the heavy duty market and the slings and accessories/options are second to none.

The extensive rail system offers choice of rail size to cope with large unsupported spans.

The bariatric twin motor unit working in tandem to support weights up to 500kgs, this system allows positioning and rotation through 360 degrees.



The bariatric twin motor unit



Bariatric twin motor unit on turntable system



Table of specifications

Functions	SwiftAir ST2000	BHM V5	Likorall Range
Location/Market Sector Recommendations	Domestic/Institutional/Acute	Domestic/Institutional	Domestic/Institutional/Acute
Motor units			
Lifting capacity	130kgs up to 280kgs	100kgs or 200kgs	200kgs up to 500kgs
Max. number of lifts per charge	60	55	65
Drive motor optional	Yes	Yes	Yes
Variable speed options	Yes	Yes	No
Slow start / stop function	Yes	Yes	Yes
Remote control option	Yes	Yes	Yes
Emergency stop - manual and powered	Yes	Yes	Yes
Lifting strap twist control	Yes	Yes	Yes
Lifting tape safety cutout on lower	Yes	No	No
Min. installed height including mini rail to spreader bar - mm	347mm	460mm	From 460mm
Lifting range	2083mm	2300mm	2100mm
Hoist motor	24v	24v	24v
Batteries	2 x 12v 5.0 Amp hours	2 x 12v 5.0 Amp hours	2 x 12v 4.5 Amp hours
Hoist motor weight	10kgs	11.4kgs	From 12kgs
Tracking systems			
Rail size options	3 sizes	3 sizes	5 sizes
Max. spans unsupported @ 200kgs	8m	6m	8m
Continuous charging liners	Yes	No	Yes
Rail colours available	Ali or any RAL colour	White	White or Ali
Curves	30, 45, 60 and 90 deg	45 or 90 deg	45 or 90 deg
Switch tracks	Yes	Yes	Yes
Auto gate system - x-y to fixed rail	Yes auto manual	Yes self powered	Yes
Auto gate system - x-y to x-y system	Yes auto manual	Yes self powered	Yes
Turntables	Yes	Yes	Yes
Wall posts	Yes	Yes	Yes
Suitable for hydro pool environments	Yes	Yes	Yes
Accessories			
Standard looped spreader bar	Yes	Yes	Yes
4 Point hanger	Tba	Yes	Tba
Weight scale	Yes	Yes	Yes
Supine stretcher	Yes	Yes	Yes
Slings	Large range available for all manufacturers.		



We believe that anyone who requires special care deserves the best care. Our mission is to provide and maintain the latest innovations to aid disabled people in their environment. Our products and services (beyond the ceiling hoist systems shown in this brochure) provide solutions whatever the application and can be found in the following additional ranges. Please call for a brochure and find out how we can get your project moving.



Lightweight patient hoists for mobility, safety & support



Providing bathroom facilities for people with disabilities



Servicing & maintenance solutions for all care environments



Patient slings & harness systems



Privacy screens & curtains for all care environments

01225 792 650
info@swifttechhoists.co.uk
www.swifttechhoists.co.uk

Head Office

SwiftTech™

Orion House, 10 Hercules Way,
 Bowerhill Industrial Estate,
 Melksham, Wiltshire SN12 6TS
 Telephone: 01225 792 650
 Fax: 01225 792 659

Website: www.swifttechhoists.co.uk
 Email: info@swifttechhoists.co.uk

An ISO 9001 Registered Firm